

DOCUMENT RESUME

ED 052 726

HE 002 356

AUTHOR Hammond, Allen L.
TITLE A Flow Model for Higher Education.
INSTITUTION Rand Corp., Santa Monica, Calif.
REPORT NO P-3922
PUB DATE Aug 68
NOTE 18p.

EDRS PRICE MF-\$0.65 HC-\$3.29
DESCRIPTORS *Decision Making, Degrees (Titles), *Doctoral Degrees, Educational Policy, Faculty, *Higher Education, *Models, Sciences, *Scientific Manpower

ABSTRACT

The flow model in this report is based on the assumption that degree production (output) is a function of the teaching input (number of faculty) but independent of the student input, except in special circumstances. The basic model deals with the flow of people from one stage of education in science to another, from undergraduate to graduate to postdoctoral status, and to professional employment either within the academic world or outside it. The model should be useful in analyzing national educational data and in answering some policy questions. This report also discusses modifications of the basic model in reference to special situations such as national draft policy, and its limitations. Economic inputs, particularly the role of federal funding and its influence on the system, are briefly considered and several policy implications and recommendations for future research are presented. (AF)

ED052726

A FLOW MODEL FOR HIGHER EDUCATION

Allen L. Hammond

August 1968

U.S. DEPARTMENT OF HEALTH,
EDUCATION & WELFARE
OFFICE OF EDUCATION
THIS DOCUMENT HAS BEEN REPRO-
DUCED EXACTLY AS RECEIVED FROM
THE PERSON OR ORGANIZATION ORIG-
INATING IT. POINTS OF VIEW OR OPIN-
IONS STATED DO NOT NECESSARILY
REPRESENT OFFICIAL OFFICE OF EDU-
CATION POSITION OR POLICY.

P-3922

E002356

A FLOW MODEL FOR HIGHER EDUCATION

Allen L. Hammond*

Consultant, The Rand Corporation, Santa Monica, California

Introduction

Despite a flurry of recent research into the processes of higher education, particularly in the sciences, many qualitative and quantitative questions of interest to the educational policymaker remain unanswered. Will there be enough faculty to teach increased graduate enrollments? How can we best spend our federal support-of-education dollars to strengthen science and engineering education? How will policy decisions to allocate available funds in certain ways affect the number of degrees produced and the quality of the education which that degree represents?

By and large the many volumes of collected educational statistics have not answered these kinds of questions, because we do not understand the underlying mechanisms of the educational process: we do not know how inputs are related to outputs in the national educational system. The numbers of students and faculty, the amount of money available, educational policy and institutional arrangements, teaching methods, and the motivation and ability of the persons involved all influence the output, but to what extent? In order to get some handle on the quantitative aspects of this problem and to begin to identify the relevant mechanisms, it is useful to see how well an analytical model can represent current trends in higher education.

Consider first just the relations between manpower variables. We might expect that the number of degrees produced (the "output") depends on the numbers of students coming into the system and on the number of faculty available (manpower "inputs"); in fact, the useful assumption

*Any views expressed in this paper are those of the author. They should not be interpreted as reflecting the views of The Rand Corporation or the official opinion or policy of any of its governmental or private research sponsors. Papers are reproduced by The Rand Corporation as a courtesy to members of its staff.

turns out to be that degree production is a function of the teaching input (number of faculty) but independent of the student input, except in special circumstances. Based on this assumption we can build a simple manpower model, similar in concept to that of Bolt,^{*} which proves to be useful in analyzing national educational data and in answering some kinds of policy questions. Modifications of the basic model will be discussed in reference to special situations such as national draft policy. Economic inputs, particularly the role of federal funding, and their influence on the system will be considered briefly. Several policy implications and recommendations for future research will be mentioned.

The Model

The basic model considered deals with the flow of people from one stage of an education in science to another, from undergraduate to graduate to postdoctoral status, and to professional employment either within the academic world or outside it. While it would also be of interest to consider later mobility within science, to model the shifts from research to teaching to administration, these subjects will not be included here (but see Intriligator and Smith in [6]). Hence the five boxes contained in the model (shown schematically with the major connecting flows in Figure 1) represent the numbers of people pursuing that particular function full time.

The flows between the various boxes of the model represent the number of persons in a given year who move from one function to another. If we assume that the fraction of those graduating with a bachelor's degree who decide to go on to graduate school changes very little from year to year, then we may describe this flow as a constant fraction of the number of bachelor's degrees over a short period of years. Thus the relationships between the flows are described by coefficients of proportionality or ratios which are assumed to be

^{*}R. Bolt in [2], see list of references.

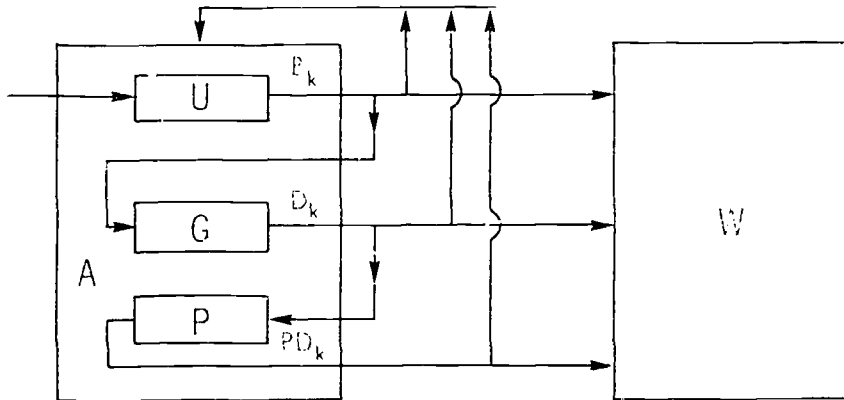

Figure 1--The flow model

Flows due to attrition (in A, W, and G) and flow due to transfer (A \nrightarrow W) are not shown in diagram.

Variables:

- A = number of (full time) academic faculty
- U = number of undergraduate students
- G = number of (full time) graduate students
- P = number of postdoctoral students
- B_k = number of bachelor degrees awarded in year k
- D_k = number of Ph.D. degrees awarded in year k
- PD_k = number of persons leaving postdoctoral status in year k
- W = number of persons employed professionally in nonfaculty positions (industry, government, institutes)

constant or at least slowly varying over a number of years.* For example, c_B is the continuation fraction of bachelor's degrees that continue their education, r_B the feedback fraction that return to the university as teachers, and w_B the fraction which seeks other employment. The same coefficients are defined with subscript D for the fractions of Ph.D. degrees and with the subscript PD for those leaving postdoctoral status.

* This assumption, of constant coefficients or linear behavior, is commonly made in models of this type but less commonly supported with empirical data, which are usually unavailable in adequate detail. For a system which is not undergoing drastic change these assumptions will not lead to large error in a short time span--perhaps five years. Applying a constant coefficient model over a longer time scale is to be done only with caution and some scepticism.

In addition to the flows indicated in Figure 1, there will be flows $a_{A k}^A$ and $a_{W k}^W$ representing the number of persons who die or retire in a given year from the academic faculty and the nonfaculty professionals. The attrition rate of postdoctorals (due to death and similar causes) is assumed negligible, while $a_{G k}^G$ represents the number of graduate students who leave school without obtaining a Ph.D., including those who leave after a master's degree. Flow due to persons transferring between A and W can be represented by $w_{A k}^A$, where w_A can also be negative; as will be indicated below, this net flow between A and W is effectively zero, and may be neglected in the analysis without affecting the results.

Mathematical Formulation

In order to obtain predictive relationships among the variables in the model, it is necessary to make assumptions about their interactions. The central assumption involved here is that the number of degrees produced is proportional to the number of faculty, the constants of proportionality for B_k and D_k being e_B and e_D . Such a relationship seems intuitively and empirically correct, at least for a short period of years, although its correctness will depend on the definition of A.

Data on national aggregates, discussed in more detail below, show that the ratios e_B and e_D are remarkably constant over a period of years, if A is taken to represent Ph.D. holding full-time faculty. More recent data from single universities, to be presented in a future paper, also bear out the assumed mechanism very well, although more so for doctorate production than for bachelor production. Mathematically the assumption here is that the degree output is independent of student manpower or economic inputs, and dependent only on the teaching manpower input, as represented by access to faculty.

It would also be desirable to formulate a similar relationship for the output of the postdoctoral group, PD_k , but the task is made more difficult by the lack of a definite terminal point to the postdoctoral period (a degree), by the fact that really adequate information on postdoctorals is not as yet available, and by the varied and

often informal types of relationships which are classified together as postdoctoral work.* Another relationship which might be assumed and which perhaps has a clearer conceptual basis is that the number of postdoctorals is proportional to the faculty (especially the research-producing faculty). Such a relationship is assumed in this model, with a proportionality constant e_p .

With the assumptions above, the difference equations which represent the model can be written down for year $k+1$ in terms of year k :

<u>assumptions</u>	<u>derived equations</u>
$B_k = e_B A_k$	$G_{k+1} = G_k(1 - a_G) + c_B B_k - D_k$
$D_k = e_D A_k$	$P_{k+1} = P_k + c_D D_k - PD_k$ (replaced by Assumption 3)
$P_k = e_p A_k$	$A_{k+1} = A_k(1 - a_A) + r_D D_k + r_{PD} PD_k$
	$W_{k+1} = W_k(1 - a_W) + w_B B_k + w_D D_k + w_{PD} PD_k$
	$PD_k = t_{PD} P_k$

The approximate expression for PD_k was used for its ease of handling, and is perhaps as accurate as present data allow; it equates the output in postdoctorals to the total number divided by the average residence time in postdoctoral status. Since the supply of undergraduates is not considered in this analysis as a limiting factor on the system, no equations for U are necessary. On substitution of the assumptions, the following set of (pairwise) simultaneous equations is obtained:

	<u>general form</u>
$A_{k+1} = A_k(1 - a_A + r_D e_D + r_{PD} e_p t_{PD})$	$= a A_k$
$G_{k+1} = G_k(1 - a_G) + A_k(c_B e_B - e_D)$	$= b G_k + c A_k$
$P_{k+1} = e_p A_{k+1}$	
$W_{k+1} = W_k(1 - a_W) + A_k(w_B e_B + w_D e_D + w_{PD} t_{PD} e_p)$	$= d W_k + e A_k$

* A model of this type was tried and found to present mathematical difficulties as well.

See Berelson [1] for a description of types of postdoctoral work.

These have unique simultaneous solutions of the form:

$$A_k = a^k A_0, G_k = b^k G_0 + [a^k - b^k] \frac{c}{(a-b)} \cdot A_0$$

$$P_k = e_p a^k A_0, W_k = d^k W_0 + [a^k - d^k] \frac{e}{(a-d)} \cdot A_0$$

It is convenient to rewrite these solutions in a different form, in terms of parameters a (a growth factor), γ and γ' (equilibrium constants), and β and β' (damping factors).*

$$A + (1 - a_A + r_D e_D + r_{PD} e_P t_{PD}), \gamma = \frac{c}{a-b} = \frac{c_B e_B - e_D}{a_G + a - 1}$$

$$\beta = \frac{b}{a} = \frac{1 - a_G}{a} \quad \gamma' = \frac{e}{a-d} = \frac{w_B e_B + w_D e_D + w_{PD} t_{PD} e_P}{1 + a_W - 1}$$

$$\beta' = \frac{d}{a} = \frac{1 - a_W}{a}$$

The system of equations can then be written:

$$A_k = a^k A_0 \quad (1) \quad G_k = a^k A_0 \left[\gamma + \left(\frac{G_0}{A_0} - \gamma \right) \beta^k \right] \quad (3)$$

$$P_k = e_p a^k A_0 \quad (2) \quad W_k = a^k A_0 \left[\gamma' + \left(\frac{W_0}{A_0} - \gamma' \right) \beta'^k \right] \quad (4)$$

Thus, the rate of growth of the whole system depends on the growth factor a , for which typical values are 1.06 or 1.07. Equation (1) then represents a rate of growth like that of compound interest formulas, with an annual "interest" of six or seven percent. The postdoctoral population (2) grows in direct proportion to the academic faculty, a direct consequence of the third assumption. Equations (3) and (4) are identical in form; for each, the damping factor (β or β') drives the system over a period of years to an equilibrium ratio between the population in question (G or W) and A , since the damping factors are less

*These equations are similar in form to those derived by Bolt [2]. Some of his nomenclature has been used.

than 1 and the second term in each expression dies out. If the initial ratios (G_0/A_0 , W_0/A_0) equal the equilibrium ratios, then there is no damping period, and the respective populations increase in direct ratio to the academic faculty.

Determination of the Variables

Only recently have educational statistics been gathered systematically, and as a consequence the data available for use in a model such as this one is at best spotty and reported in a variety of nonequivalent forms. In dealing with populations, it would perhaps be best to use full-time-equivalent (FTE) figures, as the most accurate indicator of a graduate population, for example. However, full-time populations seem to be more widely reported; in addition, the instruction and guidance of graduate students and postdoctorals, with which this model is concerned, is probably done primarily by full-time faculty, rather than part-time personnel. Hence G will be used here to mean the number of full-time graduate students in science and engineering, or in any given field.

Science and engineering, for the purposes of this paper, will be defined to include the physical sciences, engineering, mathematics, the biological sciences (excluding the health sciences), and the social sciences, psychology, agriculture, forestry, and architecture.* Although there is some variation among sources as to the inclusion of some of the smaller members such as architecture or geography, this list or a similar one is usually used in reporting science and engineering (S&E) data.

The postdoctoral population (P) as it will be used here includes three types of persons, using Berelson's categories (see [1]): research assistants (the largest group); fellows (primarily NSF supported); NIH trainees. Senior postdoctorals and medical residents are not included. To be consistent with the above paragraph it would be desirable to

*This list follows the categories of the U.S. Office of Education and the categories used by Consolazio [4].

exclude a large part of the NIH trainees, but the only available data combine them.

The academic faculty (A) as used here is the number of full-time Ph.D. S&E faculty. There are several reasons for this choice: for one, this study does not consider undergraduate education, and it is primarily, although not entirely, Ph.D. faculty which are responsible for the instruction and guidance of graduate students. For another, it is this body of faculty that is fastest growing, and hence better reflects the rate of growth of the educational system as a whole, as well as a dominant trend.* Further, as a consideration of quality in education is of interest, Ph.D. faculty undoubtedly better reflect the character and size of the major research centers and Ph.D. producers.

An important difficulty with this definition of A is that it includes quite a few Ph.D. faculty at liberal arts colleges and other schools without graduate programs, and hence does not measure exactly the size of the group which is engaged directly in graduate education. This is even more true of postdoctoral work, which is concentrated in a relatively small group of institutions, and hence the initial assumptions of the proportionality of Ph.D. production and postdoctoral population to A would not necessarily hold. At least for the whole body of S&E, however, the assumptions seem empirically justified; the case for specific fields will be considered later.

The world of professional science outside the university system, measured by W, will also be restricted to full-time, Ph.D. personnel. These are found in industry, in governmental laboratories, and in non-profit institutes. As mentioned earlier, this model did not consider flow between W and A, although there is some movement in both directions. In fact, a recent NIH study shows that job changes among Ph.D.s in the sciences occur fairly frequently, although most of these are within A

*Cartter points out in [3] that the overall percentage of Ph.D.s in higher education rose from 40 percent in 1953 to 50 percent in 1962 (all fields).

(or within W) rather than a transfer.* What transfer flows do occur balance very closely so that the net change is very close to zero.**

Values for the variables in 1961 are as follows: (overall figures for all fields of S&E, from [2] and [4]).

$$\begin{array}{llll} A = 40,000 & W = 45,000 & G = 71,700 & P = 8,800 \\ B = 128,000 & & D = 6,900 & \end{array}$$

Coefficients

The attrition rates a_A and a_W which represent the death or retirement of faculty and professional Ph.D.s are taken to be equal. Bolt (Reference [2]) finds a value of .02 from mortality tables, and Cartter finds .018 (Reference [3]). These values are unlikely to change greatly in the near future, since the bulk of Ph.D.s in S&E are still young. The attrition rate for graduate students, a_G , includes all persons who leave without a Ph.D., and hence will be a larger number. A value for this coefficient may be deduced by comparing the graduate populations in successive years, subtracting out the new first year students but adding in the Ph.D. awards from the previous year (all in full-time figures, see projections in [4], p. 214), which divided by the graduate population gives $1 - a_G$. Although very firm figures are hard to arrive at, a value of .38 seems to represent the available data, for all fields of S&E taken together. This indicates that in a given year almost forty percent of the graduate population will leave without a Ph.D., many with master's degrees, to be replaced by the incoming B. S. holders.

It is unfortunate that more detailed data could not be obtained for the graduate attrition rate, as a sensitivity analysis of the model indicates that a wide variation in its behavior with changes in a_G (and, of course with a_A and a_W , but these values are more firmly based and less likely to change). Specifically in equation (3), the value of the

*The NAS study on career patterns [7], p. 47, suggests a job change approximately every five years, on the average.

**Cartter [3] suggests a net rate of outflow from A of less than one percent, while Bolt et al. [2], find a net inflow of .1 percent.

equilibrium constant depends very nearly on the reciprocal of a_G , since the growth rate a is close to one, and hence a change in a_G of 20 percent would produce a change in the ratio of G to A of almost the same magnitude. However a survey of the statistics of M.S. production indicate that they are a reasonably steady fraction of A , which would suggest that the value for a_G does not change rapidly nor by very much.

The production ratios e_B , e_D , and e_P can be found directly from values of B , D , P , and A for a given year, and the values for 1961 are, respectively, 3.2, .17, and .22. For all fields of S&E together, the available data (primarily from Consolazio's figures [4], but confirmed in part by Bolt [2]) indicate e_B is reasonably constant, but increasing in the early 1960s by perhaps .2 a year, indicating that the rise in B.S. production is even more rapid than the rise in faculty. For Ph.D. production, e_D seems to be very constant, thus justifying the second assumption. The postdoctoral population, based on scanty data, seems for overall S&E to be increasing at about the same rate as A , or e_P a constant, but this is contradictory to the widespread impression that postdoctoral education is rapidly increasing, thus throwing some doubt on the data. In specific fields, such as physics and chemistry, e_P is certainly not a constant, as the average doubling time (in the period between 1959 and 1964) of the postdoctoral population, P , is about four and a half years, a much greater rate of increase than that of A .^{*} This period however was one of rapid expansion of federal funding for postdoctoral education, an expansion which within the last two years has abruptly terminated.^{**} During this rapid growth period the economic input of federal funding was probably the controlling mechanism for postdoctoral population; in the future the mechanism assumed in this paper may be more accurate.

The behavior of the model is not extremely sensitive to the values chosen for the production ratios e_B and e_D (e_P occurs only in connection with P and W , and hence does not affect the rest of the model); an

* See the NAS reports on physics and chemistry [8].

** I am indebted to Dean Harvey Brooks, Division of Engineering and Applied Physics, Harvard University, for information and insight into postdoctoral dynamics.

error of 20 percent in these values would cause only a small error in the system, at least if the period considered (k years) is not too large.

The continuation fractions c_B and c_D are found to have the value .31 and .27, respectively, and these values probably do not change greatly with time, although not enough data are available to support this. For bachelor degree holders, c_B is found as the ratio of full-time first-year graduate students to B of the year before (data from [4]). The ratio for Ph.D. holders is obtained by adding Bolt's feedback ratios (Reference [2]) for fellowships and for research and development, corrected to full-time basis, for 1961.

The fractions r_D and r_{PD} are found to have the values .28 and .40 for 1961 using Bolt's data corrected to full-time (Reference [2]). No other data are available for the ratios of Ph.D.s and postdoctoral who join the academic profession, at least separated in this form, although Cartter (Reference [3]) states that about half of all Ph.D.s eventually end up in the university system. The feedback ratio for postdoctorals of .40 must be regarded as a rough estimate with present data. Because data for other years are not available, it is impossible to determine whether these values are changing rapidly or not, but probably they can be assumed constant over a period of a few years.

The model is not sensitive to small changes in c_B , c_D , r_D , and r_{PD} , at least when applied over short time periods. From these values the fraction of Ph.D.s joining the work force in industry and government can be estimated. Because W is restricted to Ph.D. S&E personnel, the input of bachelor degrees into W can be ignored, and the value of w_B (in equation (4)) can be set to zero. Similarly the Ph.D. scientists within the university system who are not full-time faculty members are not counted here as part of W , and hence the fractions w_D and w_{PD} are not simply the difference between unity and the sum of the other relevant fractions (continuation and feedback).^{*} The values estimated from Bolt's data (Reference [2]) are .40 and .30 respectively.

^{*} Comparison of Bolt's data with that of Consolazio indicates that the number of Ph.D.s within the university system who are not full-time faculty is about 10,000. About 7,000 of these, according to Bolt, work in federal-contract research stations. Data are for 1961.

The average length of postdoctoral fellowships is about one year, but many fellows take a second fellowship and hence remain within P. Research assistants and trainees often remain longer. On the basis of the number of Ph.D.s entering postdoctoral status each year t_{PD} is taken to be .5, or an average residence time of two years. The rapid growth of postdoctorals indicates that this residence time may be increasing, but it is here assumed constant.

Results

The coefficients are summarized in Table 1. The parameters for use in the simplified equations (1) - (4) are calculated directly from these coefficients and are also summarized below. The growth rate of the entire system is seven percent ($a = 1.07$), that being the rate of growth of full-time Ph.D. faculty as predicted by the model. By comparing the equilibrium values above to the initial ratios $G_0/A_0 = 1.79$, $W_0/A_0 = 1.12$, the system is seen to be very nearly in equilibrium with respect to the distribution of Ph.D. professional personnel in S&E, which agrees with the assumption of very little net transfer flow between A and W. The ratio of graduate students to faculty would be expected to increase slightly after the base year (1961).

Table 1

VALUES OF COEFFICIENTS (ALL FIELDS)

a_A	.02	c_B	.31	a	1.07
a_W	.02	c_D	.27	γ	1.82
a_G	.38	r_D	.28	γ'	1.12
e_B	3.20	r_{PD}	.40	β	.58
e_D	.17	w_D	.40	β'	.92
e_P	.22	w_{PD}	.30	t_{PD}	.5

For comparison the values of the variables and the coefficients are given also for a specific field, chemistry, for which dependable data are available (Reference [8]); the variable A is here defined as

the Ph.D. faculty members in Ph.D. granting institutions (about a hundred universities), which is probably a more accurate base for the model. Also G is defined for these data as graduate students in Ph.D. programs, making a_G effectively zero. Notice the large rate of growth (29 percent) which seems so high as to cast doubt on the feedback coefficients as given. From the equilibrium coefficients it is seen that there are about $3\frac{1}{2}$ graduate students per faculty member, and 30 percent more Ph.D.s in industry and government than in the universities.

Table 2

VALUES FOR CHEMISTRY (1964)

A 2300	e_B	3.70	a 1.29	c_B .43
B 8500	e_D	.57	γ 3,6	w_D .47
G 8300	e_{PD}	.78	γ' 1.33	w_{PD} .37
D 1300	c_D	.27	β .77	wa_G 0.0
P 1800	r_D	.22	β' .76	
W (not available)	r_{PD}	.49		

coefficients not shown assumed to be the same as Table 1

A sample calculation using the model and the coefficient for all fields based on 1961 has been carried out and the results compared with more recent data where available. The model seems to represent the system adequately within the limits of uncertainty imposed by the definition of the variables. For 1970 the model would predict 73,000 Ph.D. faculty, 15,900 postdoctorals, 12,400 Ph.D. awards, and 133,000 graduate students. These figures agree well with a projection by Consolozio, (Reference [4]). If anything the model underrepresents the growth of the higher education system, which seems to be slightly exceeding even the six or seven percent growth rate predicted here, both in number of faculty and in number of graduate students.

Hence the model enables us to answer in part one of the policy-related questions posed initially--there will not be a shortage of

faculty to teach the growing wave of graduate enrollments, at least not for lack of manpower. Institutional rigidities, economic constraints, or other things not included in the model may limit the expansion of faculty to keep pace with graduate enrollments at particular institutions, but not the inherent ability of system to expand, not the supply of Ph.D.s willing to be fed back into faculty positions, if this model represents the system as accurately as it appears to.

Limitations of the Model

Perhaps the major limitation of the model is that it does not consider any constraints on the system of higher education other than the numbers of people available. Particularly, it does not consider any fiscal limitations, which may very well limit the growth of the whole system, or of a given part of it, for example, the postdoctoral population, whose expansion in recent years has been perhaps largely due to increased federal support. Consolazio (Reference [5]) notes that there is a fairly direct (empirical) relationship between federal funding and the size and growth of graduate education, which may in part be causal. Certainly federal funding imposes some kind of ceiling on the rate of growth of the many major universities and institutes which receive a substantial part of their total budget from government grants for science. An investigation of the input of federal money on the dynamics of higher education will be reported in a future paper and the relation of economic inputs to the mechanisms of the manpower system brought out in detail.

Another limitation is that implied by using data for all fields of science taken together--the overall behavior may be different from the behavior of individual fields, and the definitions of the variables necessarily include some personnel who play no part in the system under study. This is the case, for example, with Ph.D. faculty in colleges and universities without graduate programs in the sciences, who are included in the overall definition of A. Where data for specific fields are available this limitation is not important, and the chemistry data displayed in Table 2 indicate a system behavior not too different from the overall system.

This model is restricted in scope--it ignores undergraduate education and any effects it may have on the dynamics of the academic system (such as demand for faculty), it does not include any measure of the contributions to teaching of either postdoctoral students or faculty without Ph.D.s, and it does not model the dynamics of the faculty population itself (the drift towards research and administration with age). The model is independent of student input, an assumption which breaks down if the supply of students is ever sharply curtailed; for example, under the new draft policy the supply of first-year graduate students will be much reduced for two years. This situation has been studied with a simple model based on conservation laws which shows that the net result is a retardation of the growth of the whole higher educational system by almost a year.*

Lastly, this model provides no explicit measure of quality in education; if sufficiently discriminatory data were available, it would be possible to find values of the variables and the coefficients for various subgroups which could be defined to reflect quality, such as top-ranked universities, but such data does not now exist.

Summary

The use of a flow model such as this one makes it possible to obtain the dynamic relationships between the various groups involved in higher education. It provides a means of making quantitative estimates of observed trends, or analyzing the effect of particular policies on dynamic relationships. By making visible such variables as graduate student and postdoctoral population, it extends previous models of this kind which have dealt with the educational system as a unit.

The model summarizes the behavior of the educational system into a few parameters, the growth rate, the equilibrium and damping ratios, which display the essential characteristics of the system at once. Further, the equations derived for the model (1 - 4) and the parameters

*This modification of the basic model was worked out at the author's suggestion by M. Wills in connection with a course at Harvard University.

summarized in Table 2 seem to represent what empirical data are available on the system, and to predict reasonable and consistent values within the limiting assumptions of the model. As more data become available, it should be possible to extend the model to include a wider range of groups as well as apply it more accurately to specific situations. Such a model can serve to point out data of critical interest which should be gathered, as for example the attrition rate in graduate schools.

Finally, the model presented here postulates a specific input-output relation, an educational mechanism involving degree production and faculty. I feel that if we are to understand the dynamics of educational systems such mechanisms must be explored; only in this way can we hope to answer policy-oriented questions in a quantitative manner. In particular, what needs to be investigated is the relative importance of economic versus manpower inputs in controlling the output. Some initial work in this direction will be presented in a future paper.

Relatively little has been said in this paper about quality and effectiveness of education; this is not to deny the importance of assessing these factors for policy-related studies. The philosophy under which the current work on quantitative aspects of education is proceeding is that if some of the current confusion related to measurable variables and their dynamics can be reduced, comparisons of quality and discussions about measures of effectiveness can go forward more readily.

REFERENCES

1. Berelson, ., "Postdoctoral Work in Higher Education," Journal of Higher Education, Vol. 33, March 1962, p. 119.
2. Bolt, R., W. Koltun, and O. Levine, "Doctoral Feedback into Higher Education," Science, Vol. 148, 1965, p. 918.
3. Cartter, A., "A New Look at the Supply of College Teachers," to be published.
4. Consolazio, W., "Sustaining Academic Science, 1965-1975," The Educational Record, Spring, 1964, p. 210.
5. -----, The Dynamics of Academic Science, NSF 67-6, National Science Foundation, Washington, D.C., 1967.
6. Intriligator, M., and B. Smith, Some Scientific Aspects of the Allocation of Scientific Effort Between Teaching and Research, The Rand Corporation, RM-4339-PR, March 1966.
7. National Academy of Science, "Profits in Ph.D.s in the Sciences," NAS Publication 1293, 1965, p. 47.
8. -----, Physics, Survey and Outlook, NAS Publication 1295, 1966, and Chemistry: Opportunity and Needs, NSS Publication 1292, 1965.